

DESIGN NOTES

Tiny Buck Regulator Accepts Inputs from 3.6V to 25V and Eliminates Heat Sink – Design Note 268

Jeff Witt

Introduction

The LT[®]1616 is a complete fixed-frequency step-down switching regulator in a ThinSOT[™] (1mm thick SOT-23) package. It meets the needs of circuit designers who require a large input voltage range or the smallest solution possible. The LT1616 accepts an input from 3.6V to 25V, produces a low voltage output at 400mA and occupies less than 0.15in² of board space. With this wide input range, the LT1616 can regulate a large variety of power sources, from 4-cell alkaline batteries to lead-acid automobile batteries, from 5V logic supplies to unregulated AC adapters. The LT1616 is an ideal replacement for bulky (and potentially hot) TO-220 linear regulators.

Complete Switcher in ThinSOT Results in Compact Solution

Several features of the LT1616 enable this combination of small size and large voltage range. The high (1.4MHz) switching frequency allows the use of small inductors and capacitors. The current mode control circuit with its internal loop compensation eliminates additional components and handles a wide variety of output capacitors, including ceramic capacitors. The internal NPN power switch drops just 200mV at 300mA.

An external resistor divider programs the output voltage to any value above the part's 1.25V reference. The shut-down mode reduces the supply current to 1 μ A and disconnects the load from the input supply.

An internal 3.4V undervoltage lockout prevents switching at low input supply. The LT1616 will also withstand a shorted output. A fast current limit protects the circuit in overload and limits output power; when the output voltage is pulled to ground by a hard short, the LT1616 reduces its operating frequency to limit dissipation and peak switch current.

The LT1616 Produces 3.3V at 400mA

Figure 1 shows a typical application of the LT1616. This circuit generates 3.3V at 300mA from an input of 4.5V to 25V

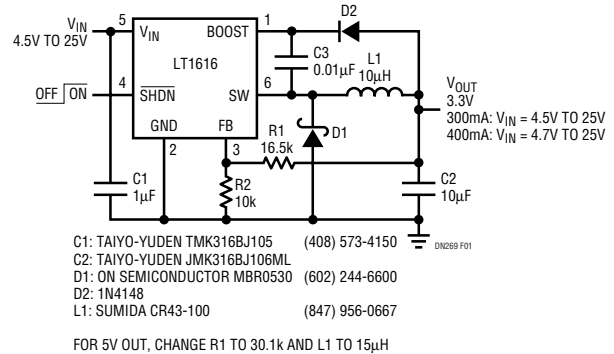

Figure 1. The LT1616 Application Accepts an Input from 4.5V to 25V and Produces an Output of 3.3V at Up to 400mA. The Circuit is Easily Modified for 5V Output

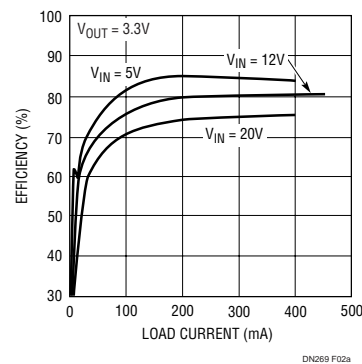

Figure 2a. Efficiency of Figure 1's Circuit, Output = 3.3V

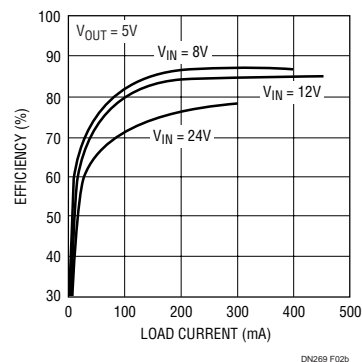

Figure 2b. Efficiency of Figure 1's Circuit, Output = 5V

LT, LTC and LT are registered trademarks of Linear Technology Corporation. ThinSOT is a trademark of Linear Technology Corporation.

25V. From a slightly more restricted input range of 4.7V to 25V, it will supply 400mA to the load. Figure 2 shows the circuit's operating efficiency at several input voltages (it also shows the efficiency for a 5V output). This wide input range allows you to generate a local 3.3V logic supply from just about any source available.

Ceramic Capacitors are Best

The LT1616's ability to work with ceramic capacitors is a significant advantage. Where achieving low output ripple from a switching regulator is concerned, low equivalent series resistance (ESR) is the most important characteristic of a capacitor. For a given package size or capacitance value, a ceramic capacitor will have lower ESR than other bulk, low ESR capacitor types (including tantalum, aluminum and organic electrolytics). With its high switching frequency, the LT1616 requires less than 10 μ F of capacitance at the output. At this value, ceramics are both smaller and lower in cost than the competing low ESR capacitors.

To summarize, using ceramics results in low noise outputs and a small circuit size. Figure 3 shows the good transient response of the circuit in Figure 1. The output recovers from a load current step in less than 30 μ s, without ringing. Because the time scale of 50 μ s per division is much longer than the LT1616's switching period, the output ripple at the switching frequency is not directly visible. The ripple appears as a slight broadening of the upper trace and amounts to just 5mV_{p-p}.

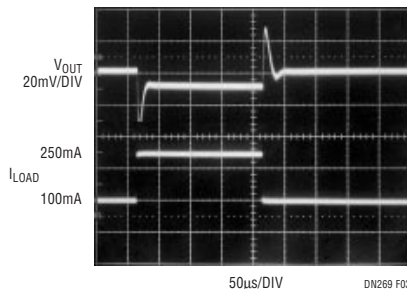

Figure 3. The LT1616 Gets Along Fine with Ceramic Capacitors, Resulting in Good Transient Response and Low Output Ripple (~5mV_{p-p}). The Upper Trace Shows Output Voltage During a Stepped Load Current (Circuit of Figure 1 with V_{IN} = 10V)

Smaller than a TO-220

The small package size and high operating frequency of the LT1616 results in a very small circuit size. In most applications, the LT1616 circuit will occupy less space than a

Data Sheet Download

<http://www.linear.com/go/dnLT1616>

linear regulator performing the same task and will dissipate much less power. For example, an LT1616 circuit converting 12V to 3.3V at 300mA dissipates only 250mW. A linear regulator will dissipate 2.6W, requiring a TO-220 style package and either moving air or a heat sink to get rid of the heat. Figure 4 compares the size of the LT1616 solution with a TO-220 package. The circuit on the left is designed for a maximum input of 16V and an output of 350mA. The circuit on the right is designed for a maximum input of 25V (requiring a physically larger input capacitor) and uses a larger inductor to keep the efficiency high at its maximum load current of 400mA. Both circuits are low profile, with a maximum height of 2.2mm for the lower cost circuit on the left and 2mm for the circuit on the right.



Figure 4. Tired of the Heat and Bulk of Linear Regulators? Switch! The Entire LT1616 Circuit Occupies Less Space Than a TO-220

2.5V Output

Figure 5 shows a 2.5V output circuit using the LT1616. The input range is limited on the low end by the undervoltage lockout (3.6V max) and on the high end by the voltage rating of the capacitors used and the maximum voltage rating of the BOOST pin.

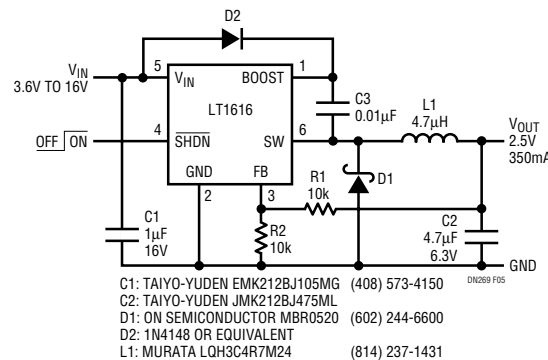

Figure 5. This Circuit Produces 2.5V at 350mA from an Input Range of 3.6V to 16V

For literature on our Switching Regulators, call **1-800-4-LINEAR**. For applications help, call (408) 432-1900, Ext. 2579